

January 2010 new product update

Logic TPS Turn Key Packaging Lines

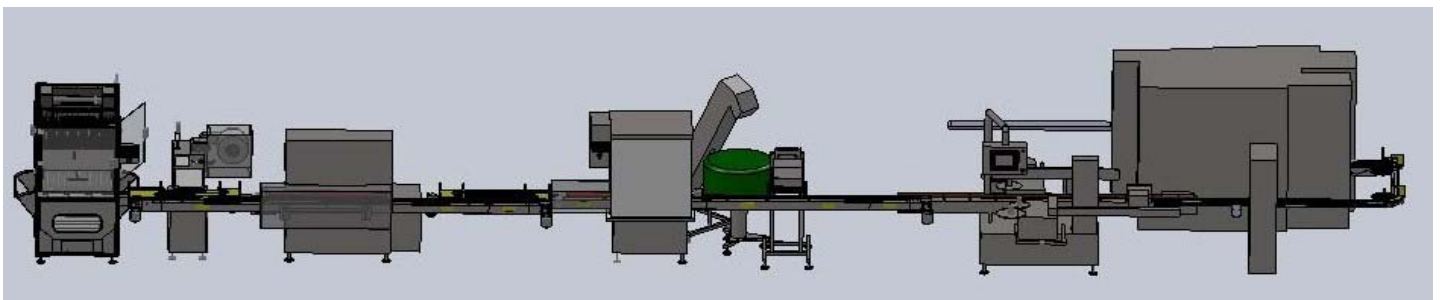

Fully automatic high speed tablet and capsule packaging line recently installed by Logic TPS at a major Generic Pharma manufacturer comprised of eight machines. Starting with the Logic SortStation container unscrambling machine, Silica gel desiccant inserter, 16 channel Tablet counter with missing tablet scan and auto bottle rejection, 4 head rotary screw capping machine, Induction sealer, labelling machine with an additional head to apply a pre-folded side leaflet, top-cert to apply as an option a pre-folded leaflet to the cap of the bottle and finally feeding into an automatic case packer. Three Omron FZ3 camera inspection systems were installed on the line to inspect and control pharma code on label and leaflets, label /leaflet presence, label/leaflet position and over print character recognition. Two further inspection systems were also installed to control foil in cap presence, cap alignment, leaflet presence and orientation prior to case packing. Space was at a premium but with the addition of two compact Logic zig-zag buffer tables with quick release change part guide systems the complete line had an overall length of only 16.8m x 4m wide and an output of 100 bottles per minute with 100 tablets



Logic TPS Turn Key Packaging Lines



The Logic range of supply includes the following;

- Container Unscrambling and Cleaning
- Silica Gel desiccant inserting
- Tablet & capsule counting, Powder filling
- Screw and Press on capping machines
- Induction Sealing
- Labelling, Sleeving, leaflet attachment
- Shrink Wrapping, Case Packing & Palletising
- Pharma Control inspection, Bar code reading
- Validation, Commissioning, Installation.
- After sales service

For customers existing lines Logic offer assistance to improve overall efficiency with customised product feeding systems, bulk elevators, conveyor buffers, new sanitary style conveyor systems with zero product traps, line efficiency monitoring, inspection and product monitoring, product grading and feeding, safety guarding. Colour coded format parts including slats for King, Lakso and Merrill slat counters, most makes of capping machine, all makes of blister packaging machine.

We also stock a wide range of pre-owned machines that are fully refurbished and tested at our facility in Burnley, Lancs. Lines can be assembled and tested prior to delivery at our facility. A blend of new and pre-owned re-conditioned machines can halve the budget of a new line.

Call us now for a stock list +44 (0)1344 750101



Hoonga Blister Packaging Lines



IN HOUSE DEMONSTRATIONS DURING FEBRUARY & MARCH 2010

HM400P & HANA 150 Compact Blister line

At our facility in Burnley we have a **HM 400P** fully servo controlled platen seal blister machine ready for demonstration to customers and available for immediate delivery. We can show product change over from PVC/ALU to ALU/ALU in 30 minutes. The photograph above shows the **HM400P** with direct blister transfer to the **HANA 150** cartoning machine. This compact solution has a overall line length of just 7.2m the **HM 400P** can produce 400 blisters per minute and other cartoning machine options are available for speeds to 300 cartons per minute.

Hoonga have also recently developed and supplied blister and cartoning machine solutions for ampoules, vials and syringes. The HM range of machines are built using European made components and Logic stock a large consignment of spare parts, over 1020 machines have been sold to more than 500 customers in 50 different countries.

- Blister packaging for tablets, capsules, vials, ampoules, syringes
- Cartoning machines for blisters & bottles
- Pillow packaging
- Stretch banding, shrink wrapping, case packing, palletising



HB 40 Stretch Banding and Shrink Wrapping Machine

- Balcony construction
- Easy film loading
- Rapid format changes
- Small footprint 1m x 1m x 1.8m high
- Suitable for cartons, blisters, bottles, cosmetics etc.
- Fully CE compliant
- Low cost solution

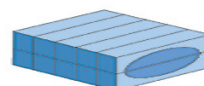
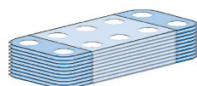
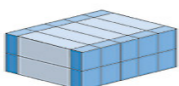

Logic Track and Trace Station



Complete carton print and inspection station for use with automated packaging lines

- Fully automated system with adjustable carton spacing and control belts
- Top and base support
- Small footprint for direct in-line connection to cartoner or check weigher
- Fully enclosed reject bin with reject verification
- Conveyor handling speeds of 4m to 40m/min (options for higher speed also available)
- Choice of printers available
- Adjustable conveyor height
- OCV/Datamatrix and code reading with LAN connectivity
- Choice of machine specifications to suit budget
- Suitable for all Track & Trace concepts, such as Italian Bollini, Belgium or French vignettes, e-pedigree, ITS (Turkey), IFAH guidelines and European EFPIA model



Logic LiftStation Tablet & Capsule Elevator



Fully Automatic product feeding device for use with blister packaging machines, tablet counters, capsule fillers etc. the LiftStation provides easy access for cleaning, quick release contact parts, fully enclosed safety guarding, dust and chip removal, HMI control for status and diagnostics. With an integrated dust and chip removal system the LiftStation can help improve the efficiency of your packaging machine.

Manufactured at our UK facility the SortStation can be customised to suit the height of your packaging machine and we provide the supply on demand signal from your machine hopper to make a very quick and easy installation.

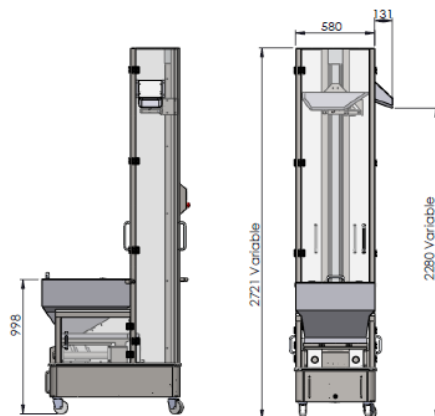

Apply Logic contact us now:

sales@logictps.com

Tel: +44 (0)1344 750101

Logic TPS Ltd. 4 Sandhurst Lodge, Wokingham Road, Crowthorne, Berkshire, RG45 7QD, UK
and

Logic TPS Ltd. Unit 17 Balderstone Close, Heasandford Ind. Est., Burnley, Lancashire, BB10 2TA, UK